

# **CABLAS** s.r.l.

Via Michelangelo Buonarroti, 52/B - 20093 Cologno M.se (Mi)

## **X-RAY FILM VIEWERS STANDARD SERIES**

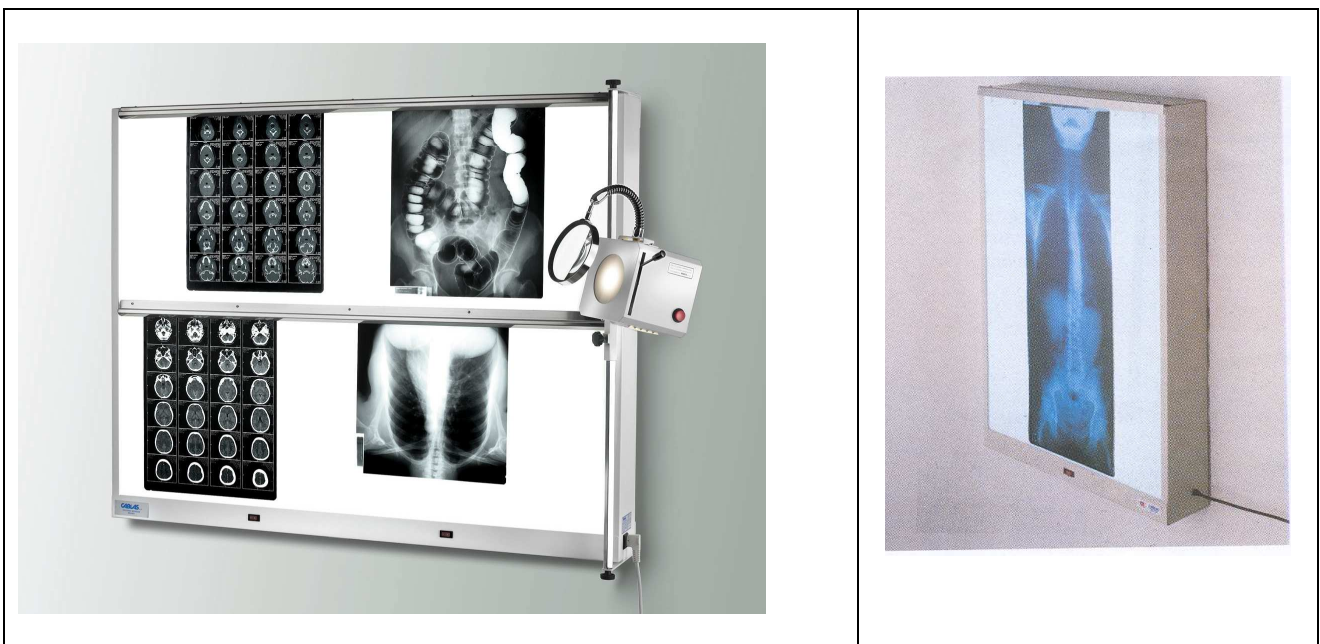

## **INSTRUCTION AND INSTALLATION HANDBOOK**



REV.01/2013

## 1.0 INTRODUCTION

Stove enamelled steel structure. Lighting is given by fluorescent tubes with colour temperature of 6000K; the detailed study of their position has allowed a homogeneous lighting on all the surface of the screen. Diffuser in smelted opaline acrylic. All the electrical components conform to the strictest Norms in force. The apparatus is equipped with a pressing rolls film holding system. All the x-ray film viewers are of Class 1.

### 1.0a DESCRIPTION

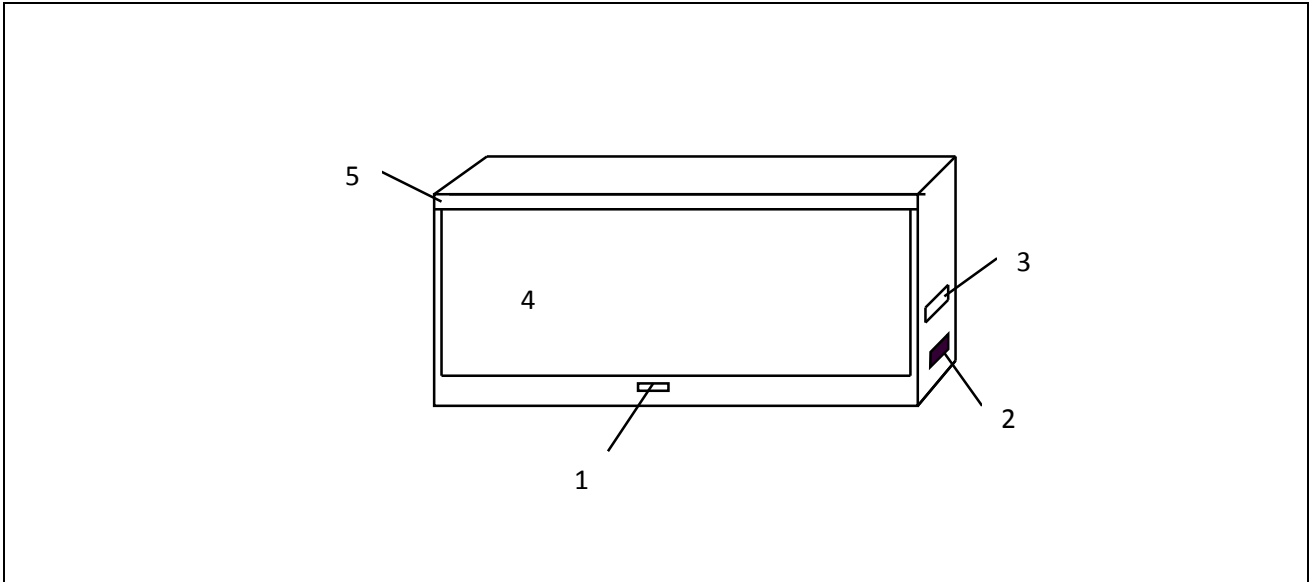

### LEGEND

- 1) General bipolar switch
- 2) Cable connection with flush fuse-holder (fuses value is shown on the data-plate)
- 3) Data-plate
- 4) Opaline diffuser
- 5) Film-holder profile

## 2.0 INSTALLATION

Before installation process, check that all the delivered material is complete in all parts.

### 2.1 Wall fixing

Wall fixing of the illuminator must be done only through expansion dowels (anti un-hooking). To proceed with fixing you have to disassemble the upper film-holder (5) and slip off the opaline diffuser (4). Inside you will see two cables with holes. The person in charge for installation has to use these two holes to fix the illuminator on the wall, using, as already told, anti un-hooking dowels with washer, in order to block the head of the screw with to the holes. After wall fixing put the diffuser and the and the film-holder to their position before using the x-ray film viewer

### 2.2 Electrical connection

#### Feeding 230V - 50Hz

The illuminator is supplied with feeding cable with plug and protection fuses. The customer must predispose an electrical socket with earth nearby the apparatus, which has to be connected to a bipolar switch with fuses suitable for each phase.

## 3.0 OPERATION

The illuminator operation is very simple. Assure you've inserted the plug into the fed electrical socket and switch on the apparatus through the apposite general switch (1). At this point the device lights up. If not control that at the socket there is a tension of 230V AC. After this control if the result is still negative, check the fuses (2) on the right side of the apparatus. If the failure persists call the nearest CABLAS technical assistance.

#### 4.0 MAINTENANCE

The x-ray film viewer doesn't need a special maintenance. We suggest a regular diffuser cleaning with a cloth in order to remove dust and prints that could "filter" light emission and adulterate the screen.

#### 4.1 REPLACEMENT OF THE TUBES

In case of internal tubes replacement, follow the below instructions:

Before approaching the apparatus, assure that the switch in "off" position and that the plug is disconnected from electrical net. To approach into the viewer, open the apparatus as described in paragraph "2.1 Wall fixing". Possible replacement of the fluorescent tube must be done with another one of the same model and power in order not to compromise the correct functioning of the electrical components. Also fusible replacement must be done with the apparatus not fed. Fusible value is shown on the data plate (4).

#### 5.0 WARRANTY

Repair or replacement of faulty parts is under warranty.

Warranty does not include indirect damages and any kind of consumer material is excluded. Moreover warranty is excluded in case of inappropriate use, incorrect use and in case of inobservance of the information contained in this manual.

**ATTENTION: this handbook must be kept during all the life of the illuminator and must be always at disposal of operators and maintenance staff.**

**Cablas srl declines every kind of responsibility on case of omission or tampering of the device.**



This apparatus is countermarked by the symbol of differentiated collection related to the electrical and electronic components material dumping. It means that this product must be brought to a differentiated collection centre in accordance with the European Directive 2002/96/CEE, in order to be recycled or demolished to reduce the possible environmental impact. For more information in this matter we suggest you to refer to the local or regional administrations. Electronic products that are not object of a differentiated collection are potentially injurious to the environment and to the human health because of the presence of dangerous substances.



## FEATURES – STANDARD SERIES

◦ OVERLAPPED HORIZONTAL SECTIONS MODEL

\* HORIZONTAL SECTIONS MODEL

^ VERTICAL SECTION MODEL

CODE	CND	N.REP.	FORM AT	OUTSIDE DIMENSION CM	WEI GHT.	N.OF TUBES.	LIGHT SECTION	W	A	FUS	Cd/m q
M-NP-30	Z110702	53750	35x43*	37x52x11	6	2-15W	1-35x43	50	0,3	1	2200
M-NP-41	Z110702	53751	40x43 *	45x52x11	6,2	2-15W	1-40x43	50	0.3	1	2200
M-NP-70	Z110702	53739	70x43 *	78x52x11	10	4-15W	1-70x43	90	0.4	1	2700
M-NP-90	Z110702	53754	90x43 *	95x52x11	12	2-30W	1-90x43	80	0.4	1	2700
M-NP-120	Z110702	53761	120X43 *	126x52x11	15	2-36W	1-120x43	90	0.4	1	2800
M-NP-150	Z110702	53764	150X43 *	156x52x11	18	2-58W	1-150x43	130	0.6	2	3000
M-NP-180	Z110702	53767	180X43 *	187x52x11	21	4-30W	2-90x43	150	0.7	2	2700
M-NP-121	Z110702	53754	90x86°	96x99x11	21	4-30W	2-90x43	150	0.7	2	2700
M-NP-122	Z110702	53774	120x86 ◦	126x99x11	28,5	4-36W	2-120x43	180	0.9	2	2800
M-NP-152	Z110702	53775	150x86 ◦	156x99x11	36	4-58W	2-150x43	270	1.3	2	3000
M-NP-182	Z110702	53778	180x86 ◦	187x99x11	42	8-30W	4-90x43	270	31.	2	2700
M-NV-010	Z110702	53967	30x90^	35x98x11	11,5	2-30W	1-30x90	80	0.4	1	3500
M-NV-020	Z110702	53976	60x90^	65x98x11	13,5	3-30W	1-60x90	120	0.6	2	3800
M-NV-030	Z110702	53979	60x120 ^	65x128x11	16,5	3-36W	1-60x120	140	0.7	2	3800

## CE CONFORMITY DECLARATION

The undersigned "CABLAS S.r.l."  
office at Via Michelangelo Buonarroti 52/B  
20093 Cologno Monzese (MI) - ITALY

DECLARES

Under own responsibility that the product

**WALL XRAY FILM VIEWER STANDARD SERIES**

Codes

M-NP-30	M-NP-41	M-NP-70	M-NP-90	M-NP-120	M-NP-150	M-NP-180
M-NP-121	M-NP-122	M-NP-152	M-NP-182			
M-NV-010	M-NV-020	M-NV-030				

Which this declaration refers, conforms to  
Directive 93/42/CEE – Medical Devices - Class 1

Moreover meets the Directive 73/23 CEE (Low tension)  
89/336 CEE (Electromagnetic compatibility).

The construction conforms to Norms  
EN 60601 -1,2 - Din 6856 -1,2

Cologno Monzese, year 2013

**CABLAS S.R.L.**  
Via Michelangelo, 52/B  
20093 COLOGNO MONZESE (MI)  
S.U.I.: Via Sormani/34 - COLOGNO M.SE  
Tel. R.A. 02 2538088 - Fax 02 27300644  
Cod. Fisc. e P. IVA 11903230156

